

## Filter-Master XL - Art. No.: 62 100 102

- » Basic unit
- » Automatic filter cleaning



### Applications

- » Also suitable for high-alloy steel
- » High levels of smoke and dust
- » Non-stop operation

### Benefits

- » High efficiency due to automatic filter cleaning
- » Exhaust arm requires less adjustment due to flow-optimised exhaust hood design
- » Best health protection for employees by use of KemTex® ePTFE filter cartridge with surface filtration
- » Safe operation by rotation field control

### Properties

- » 360 degrees rotating exhaust hood with damper
- » W3/IFA certified
- » Automatic filter cleaning
- » KemTex® ePTFE filter cartridge
- » Rotation field control
- » Exhaust arm up to 4 m

### Technical Data

<b>Art. No.</b>	<b>62 100 102</b>
<b>Filter</b>	
Filter stages	1
Filter method	Cleanable filter
Filter cleaning method	Rotating nozzle
Filter surface	10 m <sup>2</sup>
Type of filter	Filter cartridge
Filter material	ePTFE membrane
Filter efficiency	> 99.9 %
Dust classification	M
<b>Basic data</b>	
Extraction capacity	1000 m <sup>3</sup> /h
Dimensions (w x d x h)	643 x 816 x 1457 mm
Weight	155 kg
Motor power	1.5 kW
Power supply	3 x 400 V / 50 Hz
Rated current	3.2 A
Noise level	69 dB(A)
<b>Additional information</b>	
IFA-Certification	W3-Approved
IFA Certification	201023121/1140
Fan type	Radial fan
Compressed air supply	5 - 6 bar
Quantity of extraction arms	1
Exhaust arm type	flexible exhaust arm
Diameter extraction arm	150 mm
Length of exhaust arm	4 m



Suitable for alveole exchangeable dusts  
separation > 99 % of particles < 0,4 µm

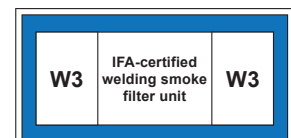

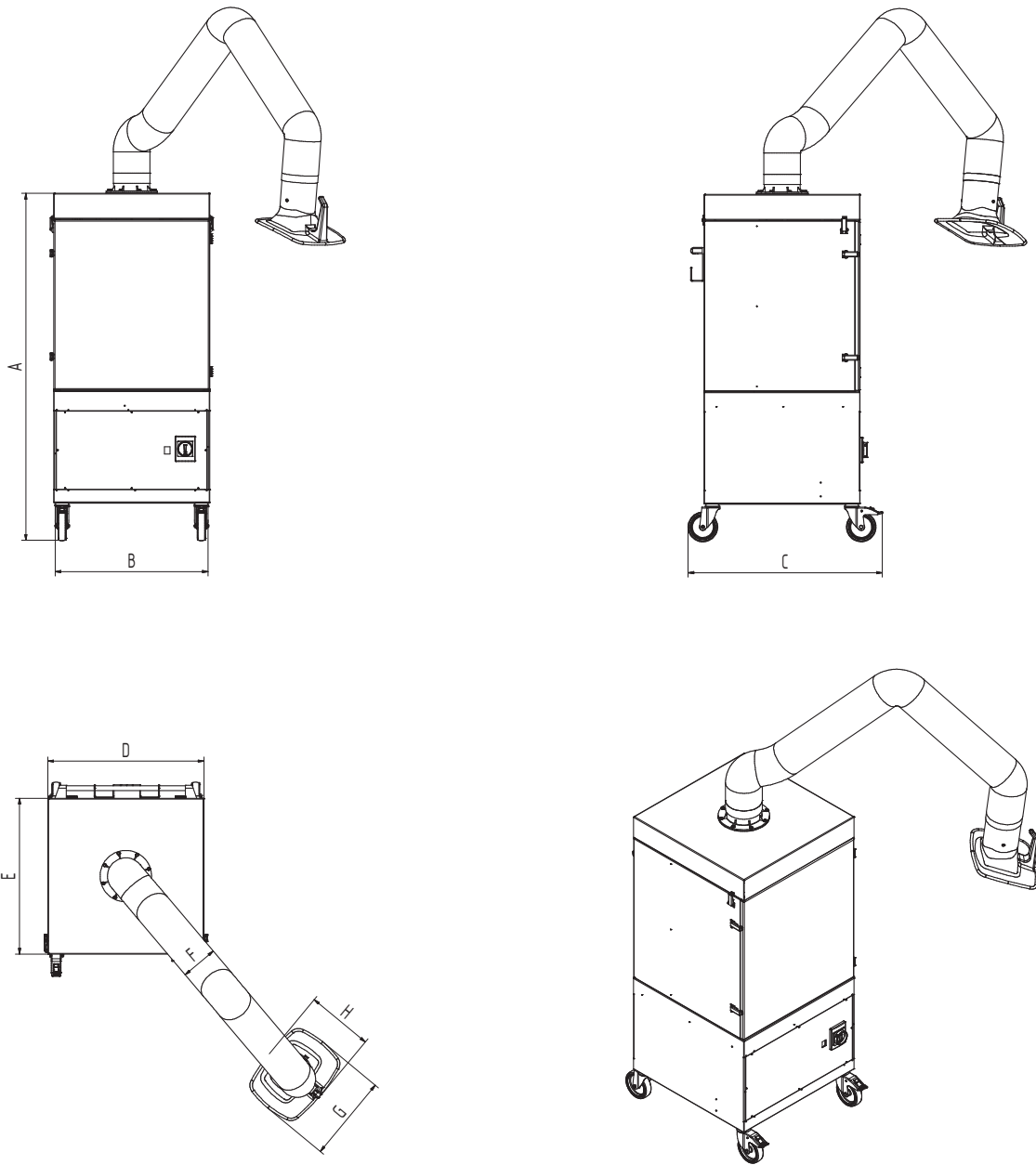

### Technical Data

Dimensions	
A	1457 mm
B	643 mm
C	816 mm
D	655 mm
E	655 mm
F	150 mm
G	360 mm
H	295 mm